

Dual Trace Oscilloscope

USER MANUAL

CONTENTS

PAGE

1. GENERAL	1
1.1 Description	1
1.2 Features	1
2. TECHNICAL SPECIFICATIONS	2
3. PRECAUTIONS BEFORE OPERATING THE OSCILLOSCOPE	5
3.1 Unpacking the Oscilloscope	5
3.2 Checking the Line voltage	5
3.3 Environment	6
3.4 Equipment Installation, and Operation	6
3.5 CRT Intensity	6
3.6 Withstanding Voltages of Input Terminals	6
4. OPERATION METHOD	8
4.1 Introduction of Front Panel	9
4.2 Introduction of Rear Panel	12
4.3 Basic Operation-Single channel Operation	13
4.4 Dual-Channel Operation	14
4.5 ADD Operation	15
4.6 Triggering	15
4.7 TIME/DIV control	18
4.8 Sweep Magnification	18
4.9 X-Y Operation	19
4.10 Calibration of Probe	20
4.11 DC BAL Adjustments	20

5. MAINTENANCE	23
5.1 Fuse replacement	23
5.2 Line Voltage Conversion	23
5.3 Cleaning	23
6. BLOCK DIAGRAM	24

SAFETY TERMS AND SYMBOLS

These terms may appear in this manual or on the product:

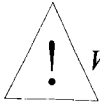

WARNING.

Warning statements identify condition or practices that could result in injury or loss of life.

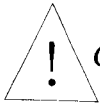

CAUTION.

Caution statements identify conditions or practices that could result in damage to this product or other property.

The following symbols may appear in this manual or on the product:



DANGER
High Voltage



ATTENTION
refer to Manual



Protective
Conductor



Earth(ground)
Terminal

1. GENERAL

1.1 Description

The 20MHz/40MHz family oscilloscope are dual-channel oscilloscope with maximum sensitivity of 5mV/DIV. The time base provides a maximum sweep time of 0.2 μ S /DIV. When magnified by 10, the sweep speed is 20nS/DIV. Each of these oscilloscope employs a 6-inch rectangular type cathode-ray tube with red internal graticule. These oscilloscopes are sturdy, easy to operate and exhibits high operational reliability.

1.2 Features

1) High intensity CRT with high acceleration voltage:

The CRT is a high beam transmission, high intensity type with a high acceleration voltage of 2KV for 20MHz and 12KV for 40MHz. It displays clear readable traces even at high sweep speeds.

2) A trigger level lock function which makes the triggering adjustment unnecessary.

3) Alternate triggering:

Even an observation of two waveforms of different frequencies, the waveform of the each channel is stably triggered.

4) TV sync triggering:

The oscilloscope has a sync separator circuit for triggering of TV-V and TV-H signals.

5) X-Y operation:

Set the switch to X-Y. Then the instrument works as an X-Y oscilloscope. CH 1 can be applied as horizontal deflection (X-axis) while CH2 provide vertical deflection (Y-axis).

2. TECHNICAL SPECIFICATIONS

MODEL		20MHz OSCILLOSCOPE	40MHz OSCILLOSCOPE	
SPECIFICATIONS				
VERTICAL AXIS	Sensitivity	5mV~5V/DIV,10 steps in 1-2-5 sequence		
	Vernier Vertical sensitivity	To 1/2.5 or less of panel-indicated value.		
	Frequency bandwidth	DC~20MHz	DC~40MHz	
		AC coupling: Low limit frequency 10Hz. (With reference to 100KHz, 8DIV. Frequency response with-3dB.)		
	Rise time	Approx.17.5nS	Approx.8.75nS	
	Input impedance	Approx .1M ohm //Approx.25pF		
	DC balance shift	Adjustable on panel		
	Linearity	$\leq \pm 0.1$ DIV of amplitude change when waveform of 2 DIV at graticule center is moved vertically.		
	Vertical modes	CH1 :CH1 single channel. CH2 :CH2 single channel. DUAL :CH1 and CH2 are displayed. ALT or CHOP selectable at any sweep rate. ADD:CH1+CH2 algebraic addition.		
	Chopping repetition frequency	Approx.250KHz		
	Input coupling	AC, GND, DC		
	Maximum input voltage	400V (DC+AC peak),AC:frequency 1KHz or lower. When set probe switch at 1:1,the maximum effective readout is 40Vpp(14Vrms at sine wave), or set probe switch at 10:1,the maximum effective readout is 400Vpp(140Vrms at sine wave).		
	Common mode rejection ratio	50:1 or better at 50KHz sinusoidal wave. (When sensitivities of CH 1 and CH 2. are set equally)		
	Isolation between channels (At 5mV/DIV range)	>1000:1 at 50KHz	>30:1 at 15MHz	>30:1 at 35 MHz
	CH2 INV BAL.	Balanced point variation: ≤ 1 DIV(Reference at center graticule.)		

SPECIFICATIONS		MODEL	20MHz OSCILLOSCOPE	40MHz OSCILLOSCOPE	
		TRIGGERING	Triggering source	CH 1, CH 2, LINE, EXT(CH 1 and CH 2 can be selected only when the vertical mode is DUAL or ADD) In ALT mode, if the TRIG. ALT switch is pushed in, it can be used for alternate triggering of two different sources.	
Coupling	AC: 20Hz to full bandwidth				
Slope	+/-				
Sensitivity.	20Hz~2MHz: 0.5DIV, TRIG-ALT: 2 DIV, EXT: 200mV		2~40MHz: 2.5 DIV		
	2~20MHz: 1.5 DIV				
	TRIG-ALT: 3DIV, EXT: 800mV				
Triggering modes	TV: Sync pulse more than 1 div(EXT: 1V)				
	<p>AUTO: Sweeps run in the free mode when no triggering input signal is applied. (Applicable for repetitive signals of frequency 25Hz or over.)</p> <p>NORM: When no triggering signal is applied, the trace is in the ready state and not displayed.</p> <p>TV-V: This setting is used when observing the entire vertical picture of television signal.</p> <p>TV-H: This setting is used when observing the entire horizontal picture of television signal. (Both TV-V and TV-H synchronize only when the synchronizing signal is negative)</p>				
HORIZONTAL AXIS	EXT triggering signal input		Approx.: 1 M ohm//approx. 25 pF		
	Input impedance		400V(DC+AC peak), AC: Frequency not higher than 1KHz		
	Max. Input voltage	0.2 uSec ~ 0.5 Sec / DIV, 20 steps in 1-2-5 sequence			
	Sweep time	+/- 3% (10° C-35° C)			
	Sweep time accuracy	≤ 1/2.5 of panel-indicated value			
	Vernier sweep time control	10 times			
	Sweep magnification	+/- 5% (20nSec~50nSec are uncalibrated)			
	x10MAG sweep time accuracy	+/- 5%, x10MAG: +/- 10% (0.2s and 1μs)			
	Linearity	Within 2 DIV. at CRT screen center			
	Position shift caused by x10MAG	Same as vertical axis. (X-axis: CH 1 input signal; Y-axis: CH 2 input signal.)			
X-Y MODE	Sensitivity	DC to at least 500 KHz			
	Frequency bandwidth	≤ 3° at DC~50 KHz			
	X-Y phase difference				

SPECIFICATIONS		MODEL	20MHz OSCILLOSCOPE	40MHz OSCILLOSCOPE
CALIBRATION VOLTAGE	Waveform	Positive-going square wave		
	Frequency	Approx. 1 kHz		
	Duty ratio	Within 48:52		
	Output voltage	2Vp-p +/- 2%		
	Output impedance	Approx. 1 K ohm		
CRT	Type	6-inch rectangular type, internal graticule		
	Phosphor	P31		
	Acceleration voltage	Approx. 2kV	Approx. 12 kV	
	Effective screen size	8x10 DIV(1 DIV=10mm(0.39in))		
	Graticule	Internal		
	Trace rotation	Provided		

Line Power Requirements

Voltage: AC 110V/220V \pm 10%

Note: AC110V needs to prearrange to my factory.

Frequency: 50Hz or 60 Hz

Power consumption : Approx. 40VA, 35W(max.)

Operating Environment

Indoor use

Altitude up to 2000m

Ambient temperature:

To satisfy specifications: 10° to 35°C (50° to 95°F)

Maximum operating ranges: 0° to 40°C (32° to 104°F)

Relative humidity: 75%RH(max.) non Condensing

Installation Category II

Pollution degree 2

Accessories

Power cord --- 1

User manual --- 1

Probes --- 2

Mechanical Specifications

Dimensions : 310 W x 150H x 455 D(mm)

Weight : Approx. 8kg (17.6lbs.)

Storage Temperature & Humidity

-10° to 70° C, 70%RH(maximum)

3. PRECAUTIONS BEFORE OPERATING THE OSCILLOSCOPE

3.1 Unpacking the Oscilloscope

The oscilloscope is shipped from the factory after being fully inspected and tested. Upon receiving the instrument, immediately unpack and inspect it for any damages that might have been sustained during transportation. If any sign of damage is found, immediately notify the bearer and/or the dealer.

3.2 Checking the Line voltage

These oscilloscopes will operate on AC 230V or 110V set by factory. Before connecting the power plug to an AC line outlet, make sure the voltage selector is set to the correct position corresponding to the line voltage. Note the oscilloscope may be damaged if it is connected to the wrong AC line voltage.



WARNING. To avoid electrical shock the power cord protective grounding conductor must be connected to ground.

Replace the required fuses shown below.

Line voltage	Range	Fuse
AC 230V	207~253	T 0.5A 250V
AC 110V	109~121	T 1.0A 250V



WARNING. To avoid personal injury, disconnect the power cord before removing the fuse holder

3.3 Environment

The normal ambient temperature range of this instrument is 0° to 40°C (32° to 104°F). Operation of the instrument above this temperature range may cause damage to the circuits.

Do not use the instrument in a place where strong magnetic or electric field exists, such fields may disturb the measurement.

3.4 Equipment Installation, and Operation

Ensure there is proper ventilation for the hole vents in the oscilloscope case.

If this equipment is used in a manner not specified by the manufacturer, the protection provided by the equipment may be impaired.

3.5 CRT Intensity

To prevent permanent damage to the CRT phosphor, do not make the CRT trace excessively bright or leave the spot stationary for an unreasonably long time.

3.6 Withstanding voltages of Input Terminals

The withstanding voltages of the instrument input terminals and probe input terminals are as shown in the following table. Do not apply voltages higher than these limits. When set probe switch at 1:1, the maximum effective readout is 40Vpp (14Vrms at sine wave). When set probe switch at 10:1, the maximum effective readout is 400Vpp (140Vrms at sine wave).

Input terminal	Maximum input voltage
CH1, CH2, inputs	400V (DC+AC peak)
EXT TRIG IN input	400V (DC+AC peak)
Probe inputs	600V (DC+AC peak)



CAUTION. To avoid instrument damage, do not exceed maximum input voltages. Maximum input voltages must have frequencies less than 1 KHz.

If an AC voltage which is superimposed on a DC voltage is applied, the maximum peak value of CH 1 and CH2 input voltages must not exceed + or - 300V. So for AC voltages with a mean value of zero volt the maximum peak to peak value is 600V.

Figure 4-1

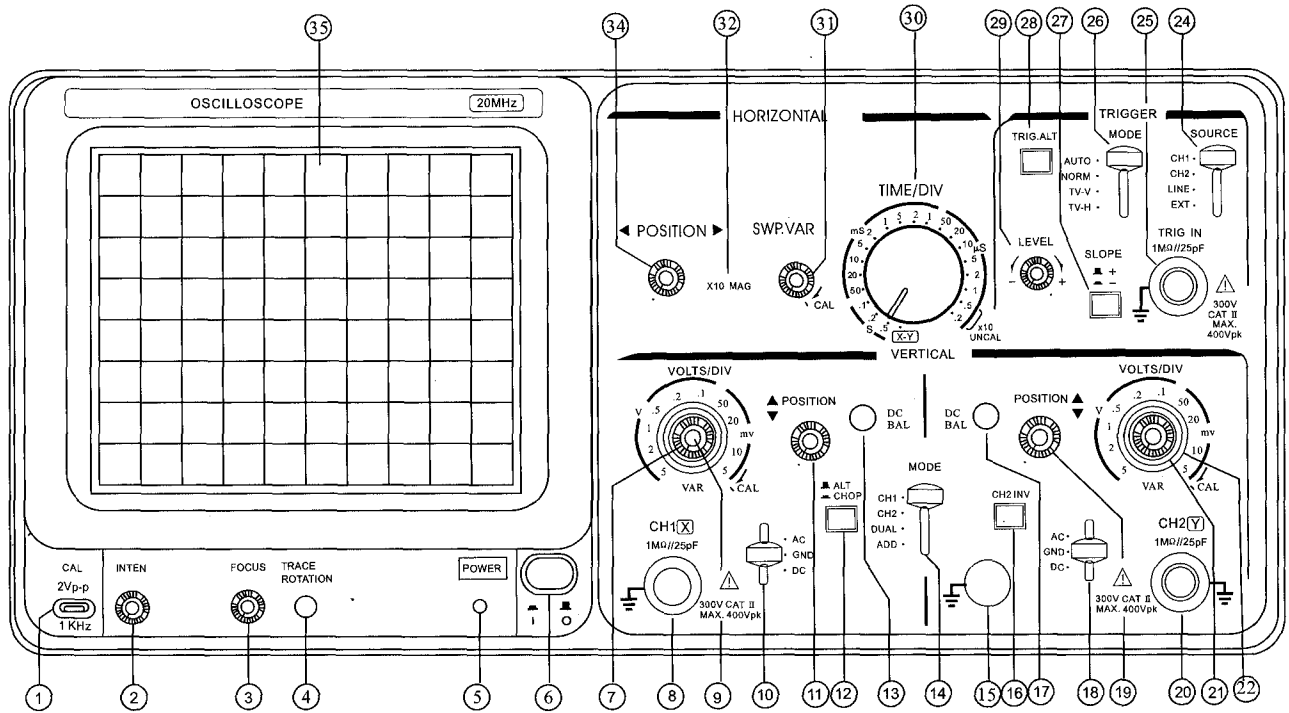
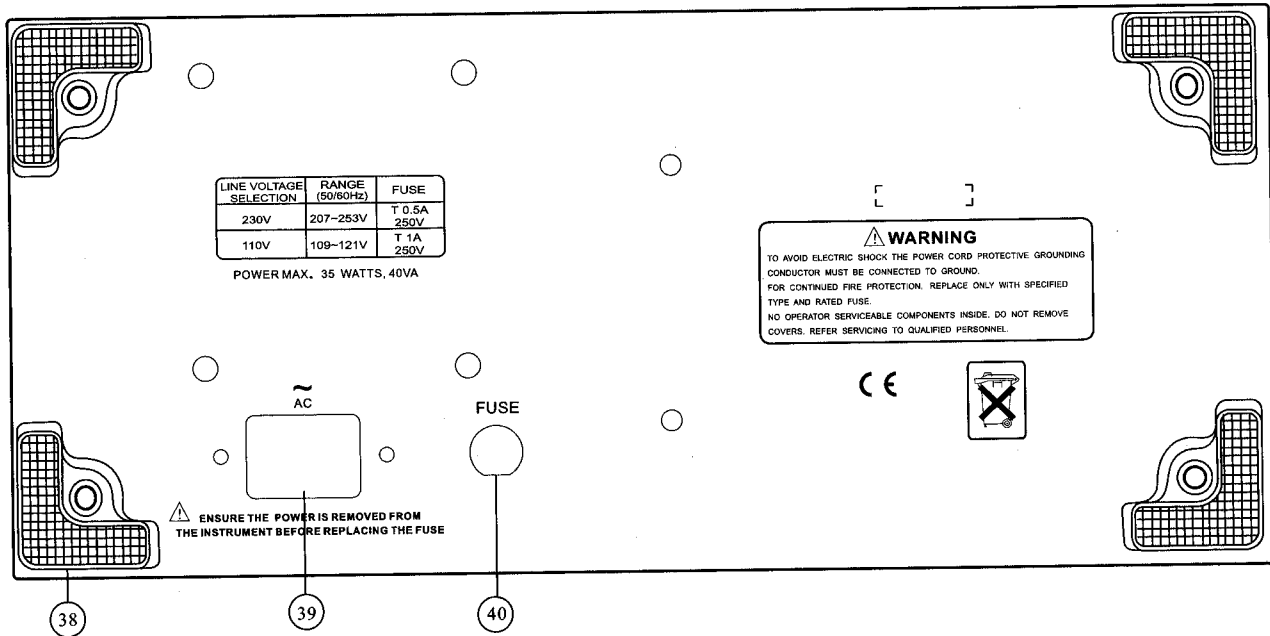

Figure 4-2



4. OPERATION METHOD

4.1 Introduction of Front Panel

CRT:.

POWER.....(6)

Main power switch of the instrument. When this switch is turned on, the LED (5) is also turned on.

INTEN.....(2)

Controls the brightness of the spot or trace.

FOCUS.....(3)

For focusing the trace to the sharpest image.

TRACE ROTATION.....(4)

Semi-fixed potentiometer for aligning the horizontal trace in parallel with graticule lines.

FILTER.....(35)

Filter for ease of waveform viewing.

Vertical Axis:

CH1(X)input.....(8)

Vertical input terminal of CH 1. When in X-Y operation, X-axis input terminal.

CH2(Y)input.....(20)

Vertical input terminal of CH 2. When in X-Y operation, Y-axis input terminal.

AC-GND-DC.....(10)(18)

Switch for selecting connection mode between input signal and vertical amplifier.

AC: AC coupling

GND: Vertical amplifier input is grounded and input terminals are disconnected.

DC: DC coupling

VOLTS/DIV.....(7)(22)

Select the vertical axis sensitivity, from 5mV/DIV to 5V/DIV in 10 ranges.

VARIABLE.....(9)(21)

Fine adjustment of sensitivity, with a factor of $\geq 1/2.5$ of the indicated value. When in the CAL position, sensitivity is calibrated to indicated value.

CH1 & CH2 DC BAL. (13)(17)

These are used for the attenuator balance adjustment. See page 26 DC BAL adjustments for the details.

▲▼ POSITION.....(11)(19)

Vertical positioning control of trace or spot.

VERT MODE.....(14)

Select operation modes of CH1 and CH2 amplifiers.

CH 1: The oscilloscope operates as a single-channel instrument with CH 1 alone

CH 2: The oscilloscope operates as a single-channel instrument with CH 2 alone.

DUAL: The oscilloscope operates as a dual-channel instrument both CH1 and CH2.

ADD: The oscilloscope displays the algebraic sum (CH 1+CH 2) or difference (CH 1 -CH 2)of the two signals.

The pushed in state of CH2 INV (16) button is for the difference (CH 1-CH 2).

ALT/CHOP(12)

When this switch is released in the dual-trace mode, the channel 1 and channel 2 inputs are alternately displayed (normally used at faster sweep speeds).

When this switch is engaged in the dual-trace mode, the channel 1 and channel 2 inputs are chopped and displayed simultaneously (normally used at slower sweep speeds).

CH 2 INV..... (16)

Inverts the CH2 input signal when the CH2 INV switch mode is pushed in. The channel 2 input signal in ADD mode and the channel 2 trigger signal pick off are also inverted.

Triggering:

EXT TRIG IN input terminal.....(25)

Input terminal is used for external triggering signal. To use this terminal, set SOURCE switch(24) to the EXT position.

SOURCE..... (24)

Select the internal triggering source signal, and the EXT TRIG IN input signal.

CH 1: When the VERT MODE switch (14) is set in the DUAL or ADD state, select CH 1 for the internal triggering source signal.

CH2: When the VERT MODE switch (14) is set in the DUAL or ADD state, select CH 2 for the internal triggering source signal.

LINE: To select the AC power line frequency signal as the triggering signal.

EXT: The external signal applied through EXT TRIG IN input terminal(25) is used for the external triggering source signal.

TRIG. ALT.....(28):

When the VERT MODE switch (14) is set in the DUAL or ADD state, and the SOURCE switch(24) is selected at CH 1 or CH2, with the engagement of the TRIG. ALT switch(28), it will alternately select CH 1 & CH 2 for the internal triggering source signal.

SLOPE(27)

select the triggering slope.

"+": Triggering occurs when the triggering signal crosses the triggering level in positive-going direction.

"-": Triggering occurs when the triggering signal crosses the triggering level in negative-going direction.

LEVEL.....(29)

To display a synchronized stationary waveform and set a start point for the waveform.

Towards: " + ": The triggering level moves upward on the display waveform.

Towards: " - ": The triggering level moves downward on the display waveform.

TRIGGER MODE.....(26)

Select the desired trigger mode.

AUTO : When no triggering signal is applied or when triggering signal frequency is less than 25Hz, sweep runs in the free run mode.

NORM : When no triggering signal is applied, sweep is in a ready state and the trace is blanked out. Used primarily for observation of signal 25Hz.

TV-V : This setting is used when observing the entire vertical picture of television signal.

TV-H: This setting is used when observing the entire horizontal picture of television signal.

(Both TV-V and TV-H synchronize only when the synchronizing signal is negative.)

Time Base

TIME/DIV(30)

Sweep time ranges are available in 20 steps from 0.2 μ S/DIV to 0.5 S/DIV.

X-Y: This position is used when using the instrument as an X-Y oscilloscope.

SWP. VAR(31)

Vernier control of sweep time. This control works as CAL and the sweep time is calibrated to the value indicated by TIME/DIV of weep can be varied continuously when Shaft is out of CAL position. Then the control is rotated in the direction of arrow to the full, the CAL state is produced and the sweep time is calibrated to the value indicated by TIME/DIV. Counterclockwise rotation to the full delays the sweep by 2.5 time or more.

X10 MAG.....(32)

When the button is pushed in, a magnification of 10 occurs.

POSITION.....(34)

Horizontal positioning control of the trace or spot.

Others

CAL.....(1)

This terminal delivers the calibration voltage of 2 Vp-p, approx.1 KHz, positive square wave.

GND.....(15)

Ground terminal of oscilloscope mainframe.

4.2 Introduction of Rear Panel

STUDS.....(38)

For laying the oscilloscope on its back to operate it in the upward position. Also used to take up the power cord.

AC Power input connector(39)

AC Power input socket. Connect the AC power cord (supplied)to this connector.

FUSE HOLDER(40)

Fuse rating is shown in Page 5.

4.3 Basic Operation--Single-channel Operation

Before connecting the power cord to an AC line outlet, make sure that the voltage selector on the rear panel of the instrument is correctly set for the AC line voltage. After ensuring the voltage setting, Set the switches and controls of the instrument as shown below:

Item	No	Setting	Item	No	Setting
POWER	(6)	Disengage position (OFF)	SLOPE	(27)	+
INTEN	(2)	Mid-position	TRIG.ALT	(28)	Released
FOCUS	(3)	Mid-position	TRIGGER MODE	(26)	AUTO
VERT MODE	(14)	CH 1	TIME/DIV	(30)	0.5mSec/DIV
ALT/CHOP	(12)	Released (ALT)	SWP.VER	(31)	CAL position
CH 2 INV	(16)	Released	◀▶ POSITION	(34)	Mid-position
▲▼ POSITION	(11)(19)	Mid-position	X10 MAG	(32)	Released
VOLTS/DIV	(7)(22)	0.5V/DIV	LEVEL	(29)	Locked
VARIABLE	(9)(21)	CAL (clockwise position)			
AC-GND-DC	(10)(18)	GND			
SOURCE	(24)	CH 1			

After setting the switches and controls as mentioned, connect the power cord to the AC line outlet, and then continue as follows:

- 1) Engage the POWER switch and make sure that the power LED is turned on. In about 20 seconds, a trace will appear on the CRT screen. If no trace appears in about 60 seconds, counter check the switch and control setting.
- 2) Adjust the trace to an appropriate brightness and image with the INTEN control and FOCUS control respectively.

- 3) Align the trace with the horizontal center line of the graticule by adjusting the CH1 POSITION control and TRACE ROTATION control (adjustable by screwdriver).
- 4) Connect the probe to the CH 1 INPUT terminal and apply the 2Vp-p CALIBRATOR signal to be probe tip.
- 5) Set the AC-GND-DC switch to the AC state. A waveform as shown in the figure 4-3 Will be displayed on the CRT screen.
- 6) Adjust the FOCUS control so that the trace image appears sharply.
- 7) For signal viewing, set the VOLTS/DIV switch and TIME/DIV switch in appropriate positions so that signal waveform is displayed clearly.
- 8) Adjust the ▲▼ POSITION and ◀▶ POSITION controls in appropriate positions so that the displayed waveform is aligned with the graticule and voltage (Vp-p) and period (T) can be read conveniently.

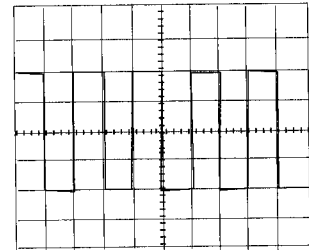

Figure 4-3

The above are the basic operating procedures of the oscilloscope. It is for single-channel operation with Ch1. Single-channel operation with CH2 can also be achieved in a similar manner. Further operation methods are explained in the subsequent pages.

4.4 Dual-channel Operation

Change the VERT MODE switch to the DUAL states so that trace (CH 2) is also displayed (The explanation in the proceeding section is of CH1). At this state of Procedure, the CH 1 trace is the square wave of the calibrator signal and the CH 2 trace is a straight line since no signal is applied to this channel yet.

Now, apply the calibrator signal to the vertical input terminal of CH 2 with the probe as is the case for CH 1. Set the AC-GND-DC switch to the AC state. Adjust vertical POSITION knobs (11) and (19) so that both channel signals are displayed as shown in Figure 4-4

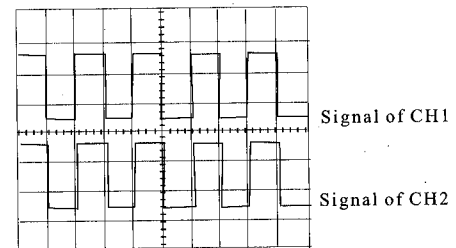

Figure 4-4

When ALT /CHOP switch is released (ALT MODE), the input signals applied respectively to CH 1 and CH2 appears on the screen alternatively at each sweep. This setting is used when the sweep time is short in 2-channel observation.

When ALT/CHOP switch is engaged(CHOP MODE), the input signals applied to CH 1 and CH 2 are switched at about 250KHz independent and at the same time appear on the screen. This setting is used when the sweep time is long in 2-channel observation

When in the dual channel operation(DUAL or ADD mode), the CH 1 or CH2 signal must be selected for the triggering source signal by means of the SOURCE switch. If both CH 1 and CH 2 signals are in a synchronized relationship, both waveforms can be displayed stationary; if not, only the signal selected by the SOURCE switch can be stationary. If the TRIG. ALT push switch is engaged, both waveforms can be displayed stationary.

4.5 ADD Operation

An algebraic sum of the CH 1 and CH 2 signals can be displayed on the screen by setting the VERT MODE switch to the ADD State. The displayed signal is the difference between CH 1 and CH 2 signals if the Ch 2 INV push switch is engaged.

For accurate addition or subtraction, it is a prerequisite that the sensitivities of the two channels are adjusted accurately at the same value by means of the VARIABLE knobs. Vertical positioning can be made with the ▲▼ POSITION knob of either channel. In view of the linearity of the vertical amplifiers, it is most advantage to set both knobs in their mid-positions.

4.6 Triggering

Proper triggering is essential for efficient operation of an oscilloscope. The user must be thoroughly familiar with the triggering functions and procedures.

(1) Functions of MODE switch:

AUTO: When the AUTO switch is engaged, automatic sweep operation is selected. in automatic sweep operation, the sweep generator free runs to generate a sweep without a trigger signal. However, it automatically switches to triggered sweep operation if an acceptable trigger source signal is present. The AUTO position is handy when first setting up the scope to observe a waveform; It provides sweep for waveform observation until other controls can properly set. Once the controls are set, operation is often switch back to the NORM triggering mode, since it is more sensitive. Automatic sweep must be used for DC measurements an signals of such low amplitude that they will not trigger the sweep.

NORM: The NORM switch provides normal triggered sweep operation. The sweep remains at rest until the selected trigger source signal crosses the threshold level set by the TRIG LEVEL control. The trigger causes one sweep to be generated. after which sweep again remains at rest until triggered. In the NORM position, there will be no trace unless an adequate trigger signal is present-In the ALT mode of dual trace operation with NORM sweep selected, there will be trace unless both channel 1 and 2 signals are adequate for triggering.

TV-V:Setting the MODE switch to the TV-V position permits selection of vertical sync pulses for sweep triggering when viewing composite video waveforms. Vertical sync pulses are selected as trigger to permit viewing of vertical fields and frames of video. A sweep time of 2 ms/DIV is appropriate for viewing fields of video and 5ms/DIV for complete frames(two interlaced fields)of video.

TV-H:Setting the MODE switch to the TV-H position permits selection of horizontal sync pulses for sweep triggering when viewing composite video waveforms. Horizontal sync pulses are selected as trigger to permit viewing of horizontal fields of video. A sweep time of about 10us/DIV is appropriate for displaying lines of video. The SWP VAR control can be set to display the exact number of waveforms desired.

This oscilloscope synchronizes with only (-)polarity, that is, the sync pulses are negative and the video is positive as shown in Figure 4-5

(2)Functions of SOURCE switch:

The displayed signal itself or a trigger signal which has a time relationship with the displayed signal is required to be applied to the trigger circuit to display a stationary signal on the CRT screen.

The SOURCE switch is used for selecting such a triggering source.



Figure 4-5

CHI/CH2: The internal trigger method which is used most commonly. The signal applied to the vertical input terminal is branched off from the preamplifier and is fed to the trigger circuit through the VERT MODE switch. Since the triggering signal is the measured signal itself, a stable waveform can be readily displayed on the CRT screen. When in the DUAL or ADD operation, the signal selected by the SOURCE switch is used as the triggering source signal.

Line: The AC power line frequency signal is used as the triggering signal. This method is effective when the measured signal has a relationship with the AC line frequency ,especially for measurements of low level AC noise of audio equipment, thyristor circuits, etc.

EXT: The sweep is triggered with an external signal applied to the external trigger input terminal. An external signal which has a periodic relationship with respect to the measured signal is used. Since the measured signal is not used as the triggering signal, the waveforms can be displayed more independent than the measured signal.

(3)Functions of TRIG LEVEL control and SLOPE switch:

A sweep trigger is developed when the trigger source signal crosses a preset threshold level. Rotation of the TRIG LEVEL control varies the threshold level . In the "+"direction, the triggering threshold shifts to a more positive value ,and in the "-" direction, the triggering threshold shifts to a more negative value. When the control is centered, the threshold level is set at the approximate average of the signal used as the triggering source.

The TRIG LEVEL control adjusts the start of the sweep to almost any desired point on a waveform. On sine wave signals, the phase at which sweep begins is variable. Note that if the TRIG LEVEL control is rotated toward its extreme+or- setting, no sweep will be developed in he NORM trigger mode because triggering threshold exceeds the peak amplitude of the sync signal.

When the TRIG SLOPE switch is set to the (+)position(up), the sweep is developed from the trigger source waveform as it crosses the threshold level in a positive-going direction. When the TRIG SLOPE control is set to the(-)position (down),a sweep trigger is developed form the trigger source waveform as it crosses the threshold level in a negative-going direction. This switch selects the slope (polarity) triggering signal as shown in Figure4-6

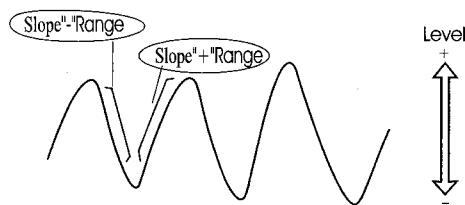

Figure 4--6

(4)Function of TRIG ALT switch:

The TRIG ALT switch is used to select alternate triggering and alternate display when the DUAL-trace VERT MODE is selected (the switch has an effect in the CH 1, CH 2, or ADD modes). In the alternate triggering mode (when dual-trace operation is selected), the trigger source alternates between channel 1 and channel 2 with each sweep. This is convenient for checking amplitudes, wave shape, or waveform period measurements, and even permits simultaneous observation of two waveforms which are not-related in frequency or period. However, this setting is not suitable for phase or timing comparison measurements. For such measurements, both traces must be triggered by the same sync signal.

When the CHOP and the TRIG ALT switches are both engaged during dual-trace operation, synchronization of the display is not possible because the chopping signal becomes the trigger. Use the ALT mode by itself, or select CH 1 or CH 2 as trigger source.

4.7 TIME/DIV control

Set the TIME/DIV control to display the desired number of cycles of the waveform. If there are too many cycles displayed for good resolution, switch to a faster sweep speed. If only a line is displayed, try a slower sweep speed. When the sweep speed is faster than the waveform being observed, only part of it will be displayed, which may appear as a straight line for a square wave or pulse waveform.

4.8 Sweep Magnification

When a certain part of the displayed waveform is needed to be expanded time wise, a faster sweep speed may be used. However, if the required portion is apart from the starting point of the sweep, the required portion may run off the CRT screen. In such a case, push in the x10 MAG button. When this has been done, the displayed waveform will be expanded 10 times to the right and left with the center of screen as the center of expansion. The sweep time during the magnification operation is as follows:

(Value indicated by TIME/DIV switch) x 1/10

Thus, the unmagnified maximum sweep speed (1 μ Sec / DIV) can be increased with the magnification as follows:

$$1 \mu\text{Sec} / \text{DIV} \times 1/10 = 100 \text{ nSec} / \text{DIV}$$

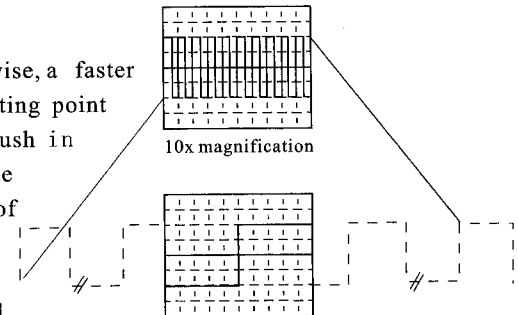

Any part can be covered by means of POSITION control

Figure 4-7

4.9 X-Y Operation

Set the TIME/DIV switch to X-Y position. Then the instrument works as an X-Y oscilloscope. Each input is applied to the instrument as follows.

X-axis signal(horizontal axis signal) :CH 1 INPUT.

Y-axis signal(vertical axis signal) :CH 2 INPUT.

Note: When high frequency signals are displayed in the X-Y operation, pay attention to the frequency bandwidths and phase difference between X and Y-axis.

X-Y operation permits the oscilloscope to perform many measurements not possible with conventional sweep operation. The CRT display becomes an electronic graph of two instantaneous voltages. The display may be a direct comparison of the two voltages such as a vector scope display of video color bar patterns. However, the X-Y mode can be used to graph almost any dynamic characteristic if a transducer is used to change the characteristic(frequency, temperature, velocity, etc.)into a voltage. One common application is frequency response measurements, where the Y-axis corresponds to signal amplitude and the X-axis corresponds to frequency.

- 1.Set the TIME/DIV control to the X -Y position (fully counterclockwise). In this mode, channel 1 becomes the X-axis input and channel 2 becomes the Y-axis input.
- 2.The X and Y positions are now adjusted using the horizontal ◀▶ POSITION and CH2 ▲▼ POSITION controls respectively.
- 3.Adjust the amount of vertical (Y-axis) deflection with the CH 2 VOLTS / DIV and VAR controls.
- 4.Adjust the amount of horizontal (X-axis) deflection with the CH 1 VOLTS/DIV and VAR controls.

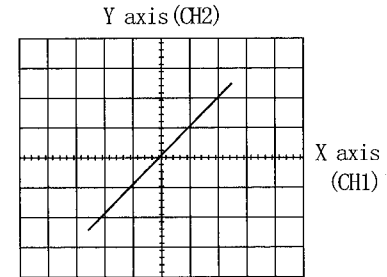
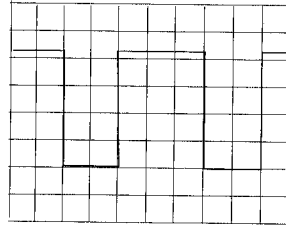

Figure 4-8

4.10 Calibration of Probe

As explained previously, the probe makes up a wide range attenuator. Unless phase compensation is properly done, the displayed waveform is distorted causing measurement errors. Therefore, the probe must be properly compensated before use. Connect the 10:1 probe BNC to the INPUT terminal of CH1 or CH2 and set VOLTS/DIV switch at 50mV. Connect the Probe tip to the calibration voltage output terminal and adjust the compensation trimmer on probe for optimum square wave (minimum overshoot, rounding off and tilt).

Figure 4-9



(a) Correct compensation

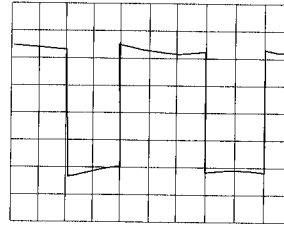

(b) Over compensation

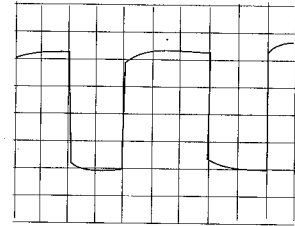

(c) Insufficient compensation

4.11 DC BAL Adjustments

The ATT balance of the vertical axis can be made easily.

- (1) Set the input coupling switches of CH 1 and CH2 to GND and set the TRIG MODE to AUTO. Then position the Base line to the center.
- (2) Turn the VOLTS/DIV switch to 5mV-10mV and adjust so that the line does not move.

5. MAINTENANCE

WARNING

The following instructions are for use by qualified personnel only. To avoid electrical shock, do not perform any servicing other than in the operating instructions unless you are qualified to do so.

5.1 Fuse Replacement

If the fuse blows, the power lamp indicators will not light and the oscilloscope will not operate. The fuse should not normally open unless a problem has developed in the unit. Try to determine and correct the cause of the blown fuse. The replace only with a fuse of the correct rating and type (see page 5)

The fuse is located on the rear panel (see fig.4-2).



WARNING For continued fire protection. Replace fuse only with 250V fuse of the specified type and rating, and disconnect power cord before replacing fuse.

5.2 Cleaning

To clean the oscilloscope, use a soft cloth dampened in a solution of mild detergent and water. Do not spray cleaner directly on to the oscilloscope because it may leak into the cabinet and cause damage.

Do not use chemicals containing benzene, benzene, toluene, xylene, acetone, or similar solvents.

Do not use abrasive cleaners on any portion of the oscilloscope.

6. BLOCK DIAGRAM

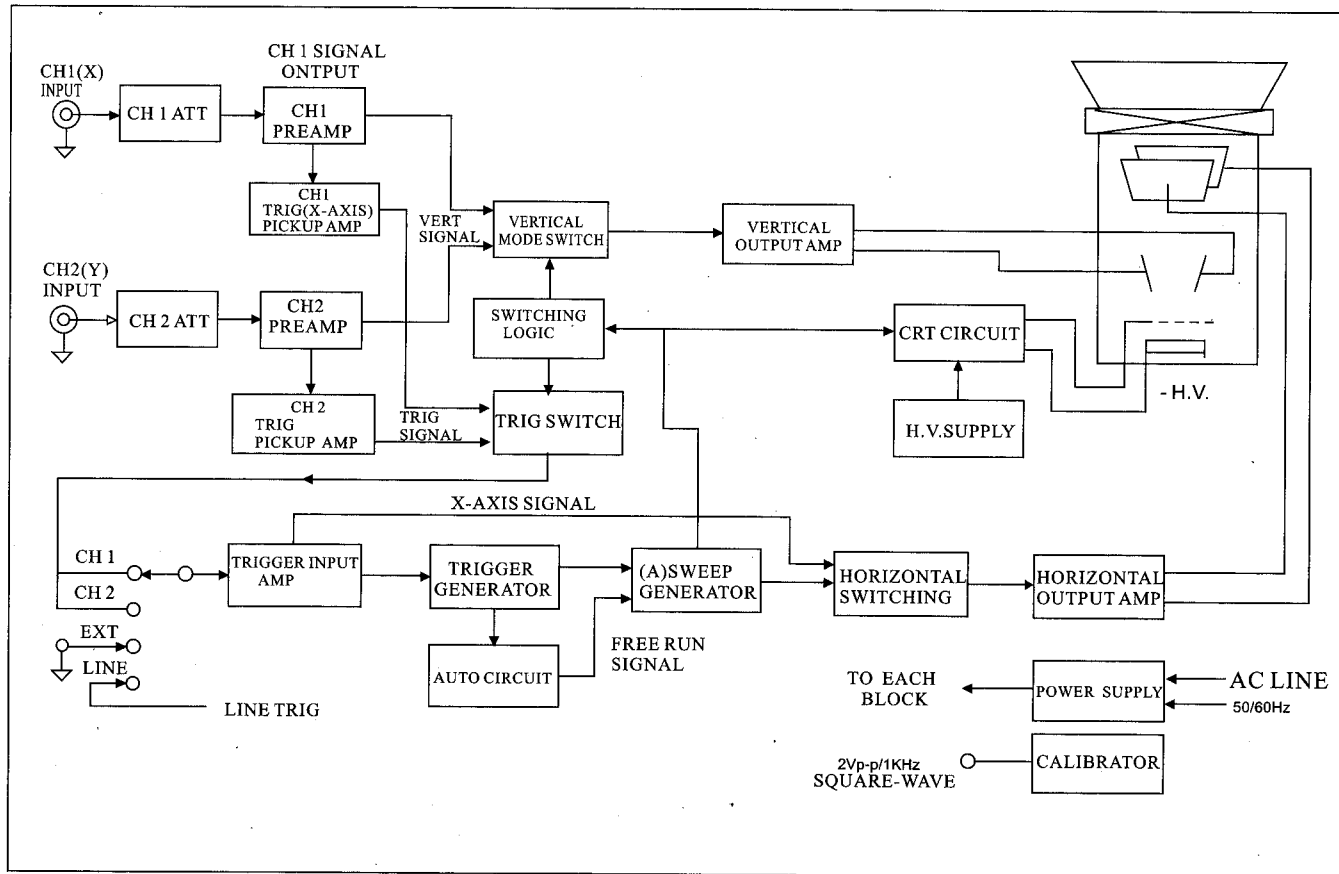

Specifications are subject to change without notice.